

Vierkant-Mehrfach-Aufnahme, Überkopf Form D2
Rectangular toolholders with multiple seats, overhead form D2
 Porte-outils, multiple, inversés forme D2

DIN ISO 10889-1
(DIN 69880)



Verwendung:
 Vorwiegend für Außenbearbeitung.
 Zum Plan Einstecken.

Application:
 Mainly for external machining.
 For face machining.

Application:
 Principalement pour usinage extérieur.
 Pour carottage.

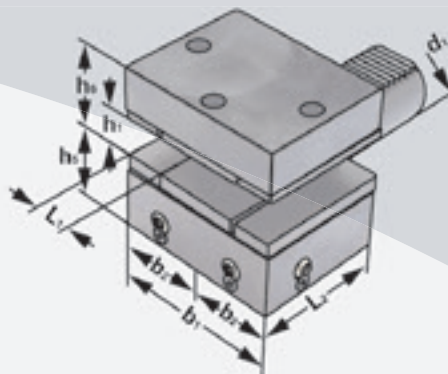

DIN ISO 10889
(DIN 69880) D2

Bestell-Nr. Order no. Référence	Abmessung Size Dimension	d ₁	b ₁	L ₂	h ₁	h ₂
309.90.12	D2 – 30 × 20 x 76	30	76	60	20	73
409.90.16	D2 – 40 × 25 x 90	40	90	72	25	90,5
509.90.20	D2 – 50 × 32 x 105	50	105	85	32	110

Ausführung: Mit einstellbarer Kugelspritzdüse und Unterlegplatte
Version: With adjustable spray nozzle and shim
Version: Avec gicleur ajustable et semelle

